

VERMEIREN

Alois (Lo-lo)

INSTRUCTION MANUAL





Instructions to the specialist dealer

This instruction manual is part and parcel of the product and must accompany every product sold.

Version: A, 2014-02

All rights reserved, including translation.

No part of this manual may be reproduced in any form whatsoever (print, photocopy, microfilm or any other process) without written permission of the publisher, or processed, duplicated or distributed by using electronic systems.

© N.V. Vermeiren N.V. 2014



Contents

Preface	2
1 Product description	3
1.1 Intended Use.....	3
1.2 Technical specifications	4
1.3 Components.....	5
1.4 Explanation of symbols	5
1.5 Accessories.....	6
1.6 For your safety	6
2 Use	7
2.1 Handset.....	7
2.2 Operating the steering casters	8
2.3 Strain relief.....	9
2.4 Power cable	9
2.5 Emergency lowering of the headrest.....	10
2.6 Metal side railings	10
2.7 Wooden side railings	11
2.8 Lifting pole.....	12
2.9 Stop notch (when available).....	12
2.10 Transfer in and out the bed.....	12
2.11 Transport	13
2.12 Cable placement	14
3 Installation and adjustment	14
3.1 Tools	14
3.2 Manner of delivery	15
3.3 Assembly.....	15
4 Maintenance	19
5 Declaration of conformity	19



Preface

First of all we want to thank you for putting your trust in us by selecting one of our products.

The Vermeiren beds are the result of many years of research and experience. During the development, special attention was given to the ease of use and the serviceability of the bed.

The expected lifetime for your bed is strongly influenced by the care and maintenance of the bed.

This manual will help you get acquainted with the operation of your bed.

Following the user instructions and the maintenance instructions are an essential part of the warranty.

This manual reflects the latest product developments. Vermeiren has the right to introduce changes without the obligation to adapt or replace previously delivered models.

For any further questions, please consult your specialist dealer.

1 Product description

1.1 Intended Use

With the Alois (Lo-Lo) model, you have acquired a nursing bed that was developed entirely for your comfort. This nursing bed offers various individual adjustment possibilities which are explained below. The ALOIS (LO-LO) bed has been designed primarily for patients in a confused state or with Alzheimer's.

The nursing bed is designed for a single adult patient at home (from 12 years, up to 135 kg max.).

The bed shall be used with a suitable mattress (min. RG 35, 120 mm thick, max. 20 kg).

The Alois (Lo-Lo) nursing bed is designed for dry indoors use on level, solid floors.

With the complete set-up, the bed can also be used for patients that are unable to move or have difficulty due to:

- paralysis
- loss of limbs (leg amputation)
- limb defects or deformations
- stiff or damaged joints
- heart insufficiencies and poor blood circulation
- balance disturbances
- cachexia (decrease in muscle)
- and also for aged persons.

When providing for individual requirements:

- body size and weight (max. 135kg)
- physical and psychological condition
- residential circumstances
- environment

should be taken into consideration.

The bed shall be used as application environment 4: "care provided in a domestic area where ME equipment is used to alleviate or compensate for an injury, disability or disease".

Your bed should only be used on surfaces where all four wheels are touching the ground and in dry spaces.

The bed should not be used as a ladder, nor is it a transport or surface for heavy or hot objects and child's bed.

When used on mats, carpeted floors or loose floor coverings, the floor covering can get damaged and it is difficult to push over such surfaces (without patient).

Use only Vermeiren approved accessories.

The manufacturer is not liable for damage caused by the lack of or improper service or as a result of not following instructions from this manual.

Compliance with the user and maintenance instructions are an essential part of the guarantee conditions.

Visually impaired people can contact the dealer for the instructions for use.

1.2 Technical specifications

Technical terms below are valid for the bed in standard settings and fully assembled bed. If other accessories are used, the tabulated values will change.

Make	Vermeiren	
Address	Vermeirenplein 1/15, B-2920 Kalmthout	
Type	bed	
Model	Alois (Lo-Lo)	
Maximum occupant mass	135 kg	
Description	Min.	Max.
Length	2070 mm	
Width	1070 mm	
Total height (without lifting pole)	660 mm	1140 mm
Total height (with lifting pole)	1550 mm	2001 mm
Length head end	865 mm	
Length feet end	1114 mm	
Height adjustment of the bed slatted frame	200 mm (without mattress)	720 mm (without mattress)
Folded length	2006 mm (bed); 980 mm; 1820 mm (accessories) or 2006 mm (bed); 150 mm (accessories)	
Folded width	300 mm (bed); 130 mm; 140 mm (accessories) or 300 mm (bed); 150 mm (accessories)	
Folded height	930 mm (bed); 800 mm; 520 mm (accessories) or 930 mm (bed); 770 mm (accessories)	
Total mass	Approx. 98 kg	
Adjustment of the back section	65°	
Max. thigh angle	30°	
Max. angle for lower leg	-16°	
Max. safe load	170 kg	
Lifting pole	Nominal load 80 kg	
Mattress	Min. RG 35, thickness 120 mm, 2000 x 900 mm, max. 20 kg	
Under clearance for patient hoist	130 mm	
Steering casters (4 pieces)	Ø 75 mm , can be locked	
Motor of slatted frame	LA311779-00, Linak	
Motor head end	LA312100-2010002E, Linak	
Motor feet end	LA312100-2005002D, Linak	
Handset	HB73H15-050028 (997AL) or HB72015-029028 (998AL), Linak	
Control box (transformer)	CB9160AE4-00019 (997AL) or CB9260AE2-00020 (998AL), Linak	
Nominal voltage, transformer	Input: 230 V~, ± 10%, 50 Hz, max. 1,5A, Output: 24V ---, max. 70 VA	
Period switched on	10% or maximum 2 minutes followed by 18 minutes not in use	
Noise level	48 dB(A)	
Class / Kind of protection	Protection class II, application part Type B / IP66 (spray protection)	
Storage and use temperature	+ 5 °C	+ 40 °C
Storage and use humidity	30%	70%

We reserve the right to introduce technical changes. Measurement tolerance ± 15 mm / 1,5 kg / °

Table 1: Technical specifications

The bed complies to the requirements set up in:

- EN 1970: Adjustable beds for disabled persons: Requirements and test methods
 EN 1970+ A1: Adjustable beds for disabled persons: Requirements and test methods
 EN 60601-2-38/A1: Medical electrical equipment - Part 2-38: Particular requirements for the safety of electrically operated hospital beds

1.3 Components

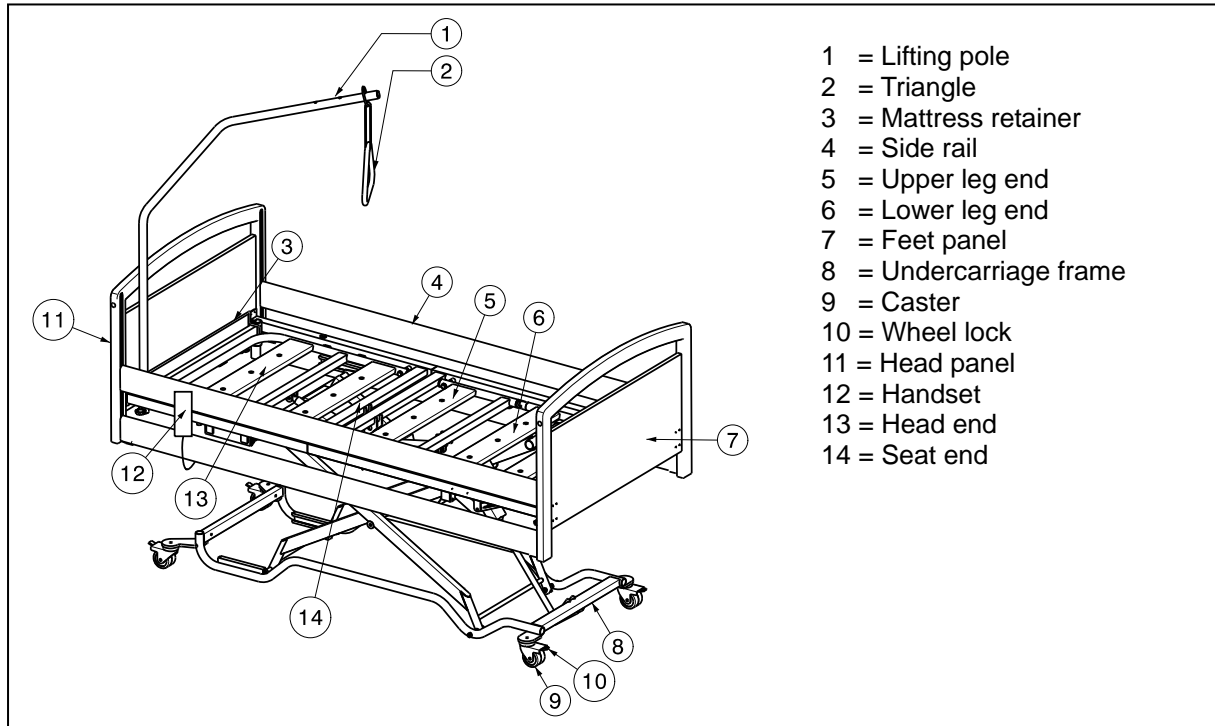

1.4 Explanation of symbols



Maximum mass



CE conformity



Safety instructions



Observe the instructions for use



The correct procedure or method of use



Incorrect procedure or method of use



Protection class II



Type B application











1.5 Accessories

⚠ WARNING: Precautions shall be taken if accessories not listed below are used.

- Third bedside wood

1.6 For your safety



- ⚠ Carefully read the instruction manual before using the nursing bed.
- ⚠ Place and use your nursing bed only on straight and level surfaces and ensure that all four steering castors stand securely on the floor.
- ⚠ When the bed is placed in position, make sure that no obstacles are present inside the entire adjustment range.
- ⚠ If the patient is not supervised, the bed must be adjusted beforehand to the lowest position to reduce the danger of injury by falling when getting into, getting out of, or lying on the bed.
- ⚠ If the patient is not under supervision, the side railings on both sides should be raised to the highest position. The railings may only be lowered on one or both sides when a supervisor is present.
- ⚠ Watch your hands when assembling, disassembling or using the bed -- danger of squashing !
- ⚠ Make sure your limbs do not become trapped in the frame when adjusting the height – Danger of crushing!
- ⚠ When transporting the bed, grasp it only by solid frame parts and wooden parts.
- ⚠ All four steering castors must always be locked before using the nursing bed.
- ⚠ Medical-electrical treatments are forbidden inside the nursing bed !
- ⚠ Do not lean against or on the side railings -- danger of accidents !
- ⚠ Avoid leaning out sideways with the upper body -- danger of accidents !
- ⚠ Do not rest your legs on other objects -- danger of accidents !
- ⚠ When adjusting hinges, joints or other clamps, make sure that no body parts or objects are present -- danger of squashing !
- ⚠ Do not place your hands between the frame and the mattress when adjusting leg or backrests -- danger of squashing !
- ⚠ Use only power sockets conforming to VDE (220 V / 230 V, 50 Hz) for plugging in.
- ⚠ Plugs must only be pulled out by grasping the plug itself; never pull on the cable.
- ⚠ The nursing bed must only be used in dry rooms.
- ⚠ Only use mattresses which comply with the prescriptions of the bed manufacturer.
- ⚠ If the lifting pole is distorted, it should be replaced.
- ⚠ The side railings must be fitted even if the relevant side is situated against the wall.
- ⚠ Do not undertake repairs on your own -- danger of accidents ! (Only have repairs done by authorised or trained personnel.)
- ⚠ Do not open any housings of the driving system -- danger of accidents !
- ⚠ A patient may only be conveyed in the nursing bed when lying in the lowest horizontal position.
- ⚠ Make sure that all power cables are laid without kinks, shearing or other mechanical damages.

-  All cables should be laid without making contact with the floor and with no kinks.
-  No additional mechanical or electric appliances may be used or fitted.
-  Servicing, inspection, repairs and disinfection should only be undertaken by authorized, trained persons.
-  Use only genuine replacement parts of the manufacturer for your nursing bed.
-  Do not exceed the maximum load of 135 kg as stated by the manufacturer.
-  The use of open flames like candles or glowing objects like cigarettes is forbidden inside the nursing bed.
-  Replace the side railings if they are bent or broken, otherwise there is a risk of the patient falling out of the bed.
-  Use of your bed could influence other electrical devices (noises). Avoid using such devices at the same time.
-  Obey all safety and operational instructions.
-  The medical bed shall only be used with a hoist that can positioned under the limited space of the medical bed.
-  Keep children a safe distance from the bed.

2 Use

This chapter describes the everyday use. **These instructions are for the user and the specialist dealer.**

The bed is delivered fully assembled by your specialist dealer. The instructions intended for the specialist dealer on how to set up the bed are given in § 3.

-  **WARNING: Avoid squeezing from routing cables of other equipment between parts of the medical bed.**
-  **WARNING: The medical bed shall only be used with a patient hoist that can positioned under the limited space of the bed.**

2.1 Handset

-  **CAUTION: Risk of injury - Adjustments made by the patient must be allowed under supervision only.**

The height of the bed surface, the angle of the backrest and the knee-bend angle can be adjusted with the handset. After use the handset needs to be hung on the side rail or placed in the flexible holder on the mattress slatted frame.

Following adjustments can be used:

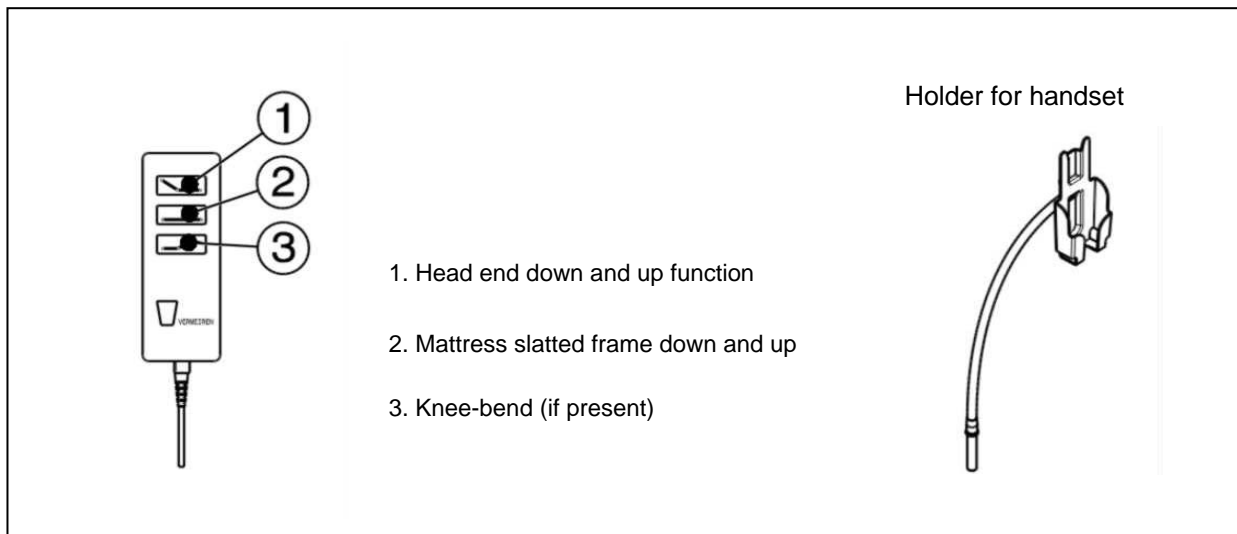

2.2 Operating the steering casters

⚠ WARNING: Good operation of the steering casters is influenced by wear and contamination of the tires (water, oil, ...) – Check the condition of the tires before each use.

⚠ WARNING: The steering casters can wear – Check the operation of the steering casters before each use.

⚠ WARNING: Danger of accidents - All steering casters should always be braked. If only one caster is braked, the free running wheels rotate around the locked one.

All steering wheels can be locked to prevent involuntary rolling.

- **Securing (A)**
Push the surface of the tilting lever downwards by foot until it brakes the wheel.
- **Releasing (B)**
Push the surface of the tilting lever forwards by foot until the wheel is released.

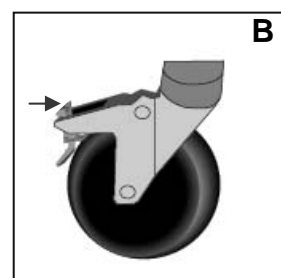
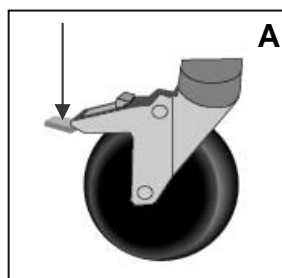

2.3 Strain relief

⚠ WARNING: Do not remove the relief unit.

⚠ WARNING: Nothing must be fitted to or hung on the relief unit.

Below the spar of the head slatted frame there is a socket for the tightening of the relief unit.

- Insert the relief unit of the power cable (4) into the suspension (3).
- Pull the desired length of the power cable (1) in such a way that the power cable (2) can be laid under the slatted frame without sagging. Be careful to avoid that the cable (2) come under the traction in any adjustment position.
- Fasten the power cable by properly tightening the relief unit of the power cable (4).
- Fasten the position of the relief unit by properly tightening the fixing screws (5).

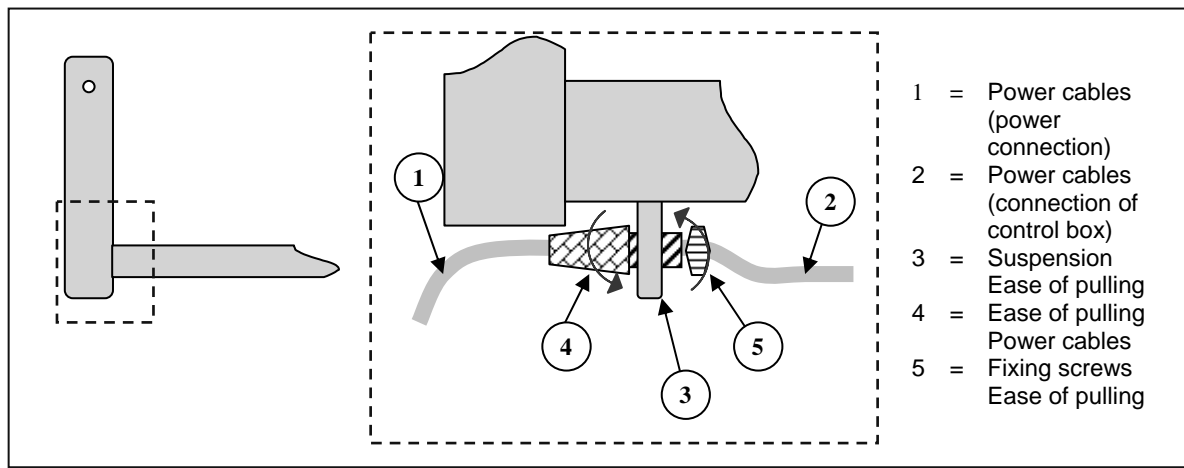

2.4 Power cable

⚠ WARNING: Nothing but the power cable should be suspended here.

⚠ WARNING: The power cable can be damaged - The power cable must be carefully positioned without kinks, pulling, shearing or other mechanical damages and without making contact with the floor.

To ensure that your power cable stays properly functional and in a technically secure condition even after protracted use, and in the case that you do not operate your bed electrically, we have at the spar of the slatted frame (next to the cable grip at the head end) provided a holder where you might safely leave the rolled-up cable beneath the nursing bed.

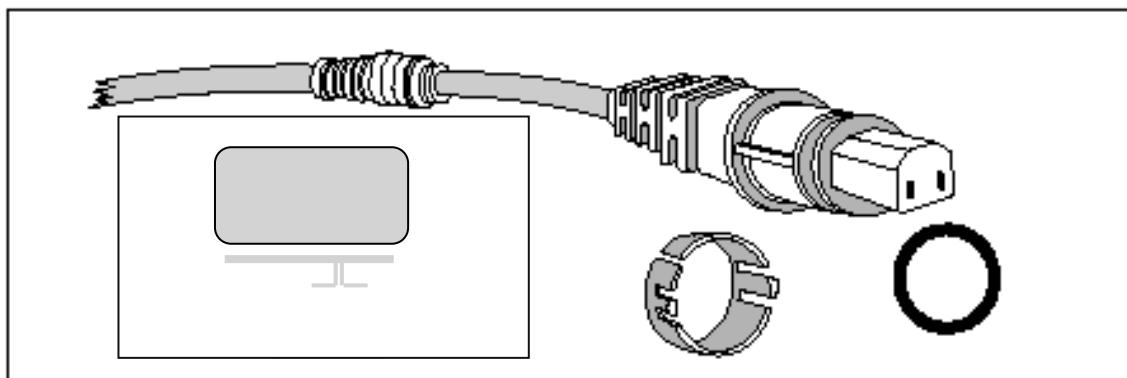

2.5 Emergency lowering of the headrest

⚠ WARNING: Risk of squashing - Check that there are no objects or body parts between the headrest and the frame.

The headrest can be lowered manually (emergency lowering in the case of motor failure).
Emergency lowering is only permitted if at least two persons are available.

- Procedure:
1. Turn the securing loop of the upper motor over.
 2. One person holds on to the side of the headrest while another person pulls the securing bolts out and removes the motor from its suspension.
 3. Then the headrest can be lowered.

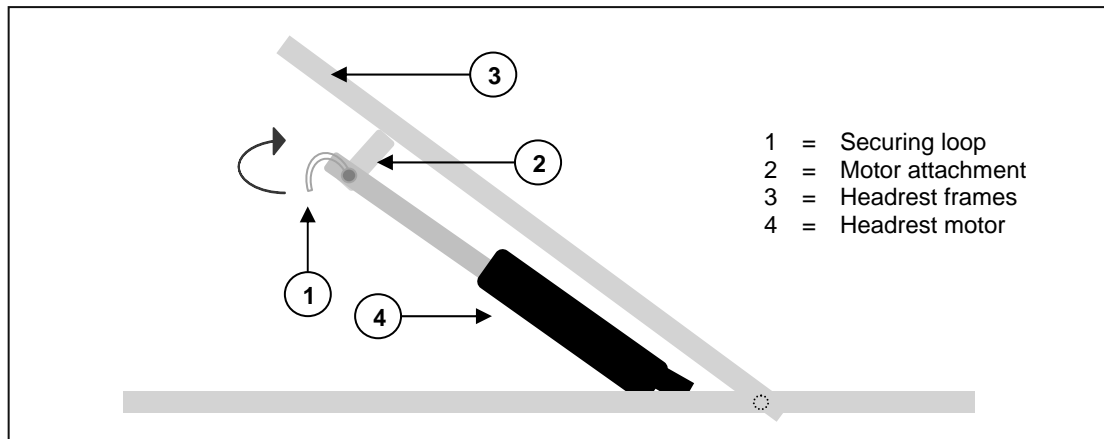

2.6 Metal side railings

You can lower the side railings by pulling down the lever (1) at the bottom of the side rails. You can then lower the side rails.

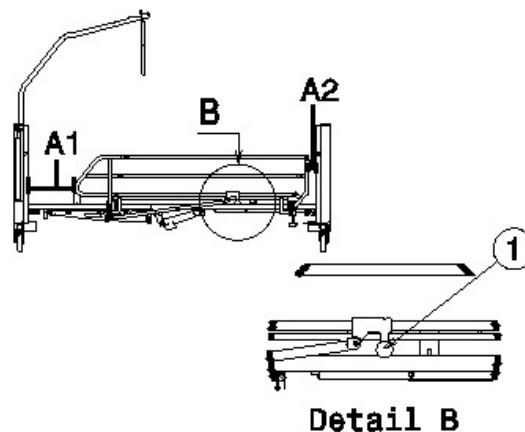

2.7 Wooden side railings

The side railings can be lowered on one side.

- Lowering

 **WARNING: Risk of squashing - Secure the side railings against falling involuntarily.**

 **WARNING: Risk of squashing - No objects or body parts may extend above the lying surface!**

 **WARNING: Risk of injury - Do not lower the side railings on one side if the patient is not supervised.**

Raise the upper side slat gently, press the arresting knob on the side of the headrest or foot-end and lower the side railing slowly. (Always take hold of the upper wooden slat only !)

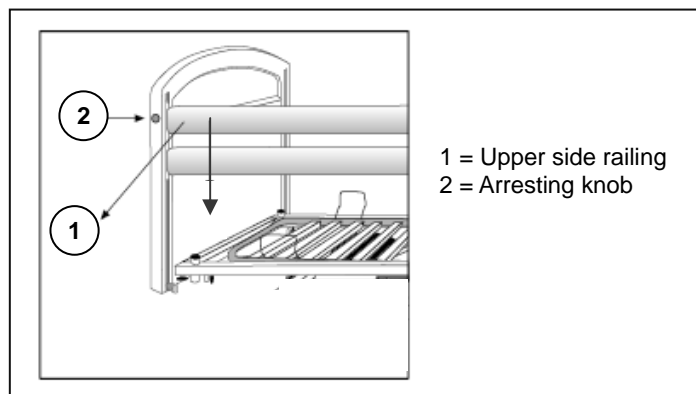

If raising the side railings or covering these are required for additional security of the patient (e.g. very skinny patient), it should be noted that no functions of the bed should be impaired, nor the CE-conformable implementation as when first delivered.

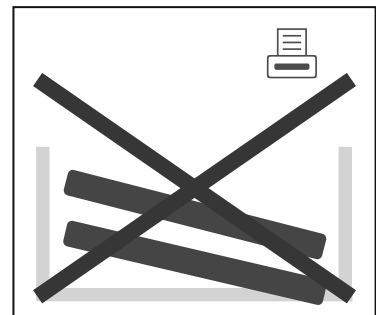
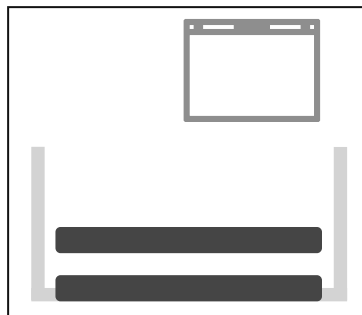
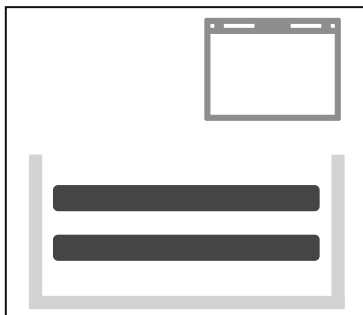

2.8 Lifting pole

The lifting pole can be mounted on either side of the headrest (use only for Alois (Lo-Lo)!).

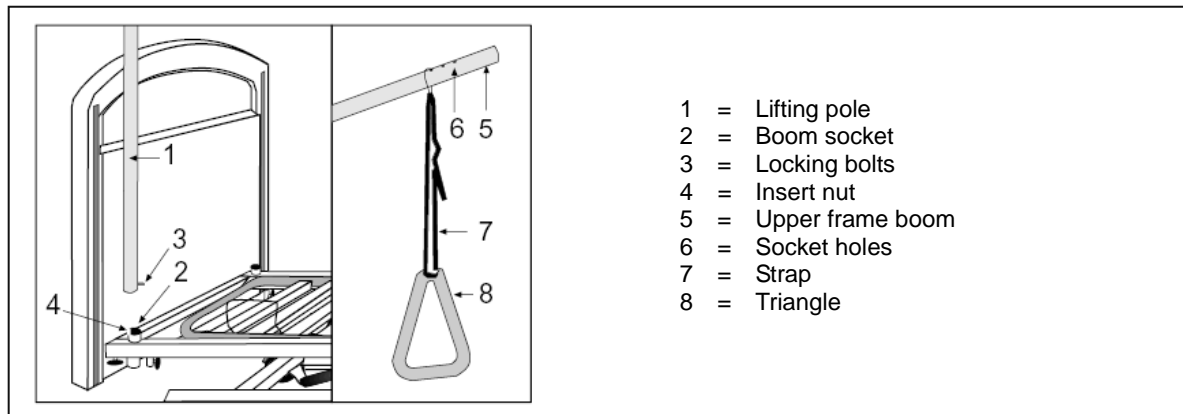

- Insert the boom (1) as far as it will go into the relevant socket (2).
- Let the arresting bolts (3) slide into the groove (4).
- Pull the metal loop over the end of the upper frame (5) until the bolts engage one of the three socket holes (6).
- Also pull strap (7) into the metal loop and through the triangle (8); then fix its length. Secure the strap.

2.9 Stop notch (when available)

⚠ CAUTION: Risk of injury - No people or objects allowed close to where adjusting is being done.

To adjust the lying surface of the lower leg, grip the foot-end toggle strap in the middle of the frame. Pull the lying surface of the lower leg to the desired height. The stop notch locks in distances of approx. 2cm. To lower the lying surface of the lower leg, use the foot-end toggle strap and pull it to the upper position. The stop notch will now stop locking and you can slowly completely let down the lying surface of the lower leg until it reaches the bed frame.

Perform adjustments only by means of the foot-end toggle strap to avoid tipping over or damage to the frame adjusters.

2.10 Transfer in and out the bed

⚠ CAUTION: In case you cannot perform the transfer in a safe manner, ask someone to assist you.

1. Position you as close as possible to the bed.
2. Check the brakes from the bed are in the on position.
3. Remove or fold down the side railings of the bed.
4. Transfer to/from the bed.

2.11 Transport

- ⚠ WARNING: Risk of injury – See that the bed is attached properly. So you can avoid injury from the passengers during collision or sudden braking.**
- ⚠ WARNING: Risk of injury – Use for attaching the bed and passenger NEVER the same seatbelt.**
- ⚠ WARNING: Risk of injury – The bed is not intended to be used for transporting patients.**
- ⚠ WARNING: Risk of injury – Patients may only be transported when recumbent in the lowest horizontal position.**

To avoid damage when transporting, the lifting pole should be detached. Remove the power cable and make sure that no cables hang near the floor.

If you are transporting the bed over a long distance, you can use the transport set.

Assembling the transport set.

- Lower the bed into its lowest position and then remove the power cable from the power socket.
- Move the head and feet panels from the mattress slatted frame.
- Insert one transport kit (1) into the mattress slatted frame (2) (e.g. head end). Secure the transport kit with the star handle (3).
- Insert the other transport kit into the mattress slatted frame on the other side (e.g. feet end). Secure the transport kit with the star handle.
- Turn the two remaining star handles back into the intended positions on the mattress base.
- Then turn the mattress slatted frame on the side where the transport kit is mounted thus moving the transport set's castors downward. The bed can now be pushed easily on the rolling castors.

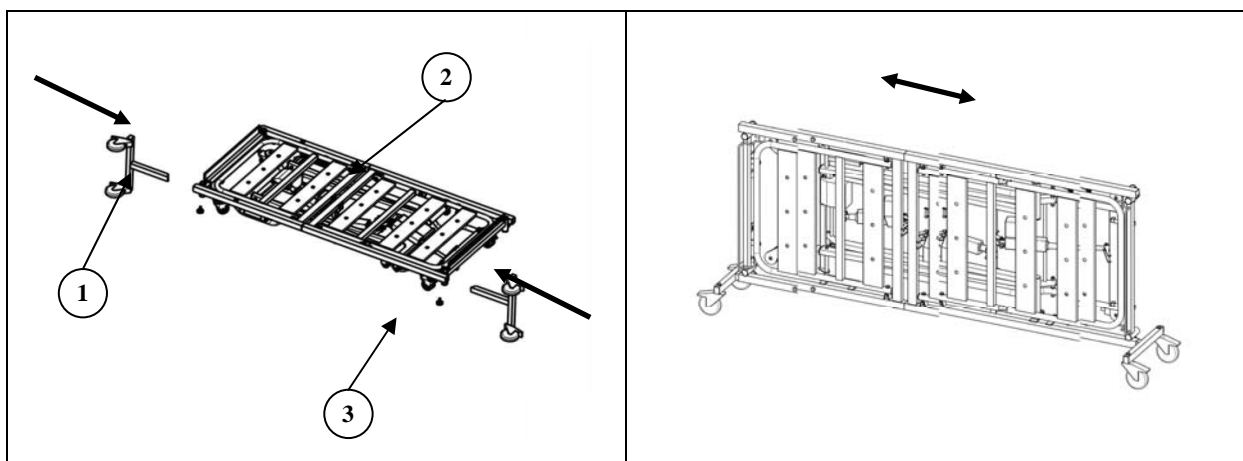

2.12 Cable placement

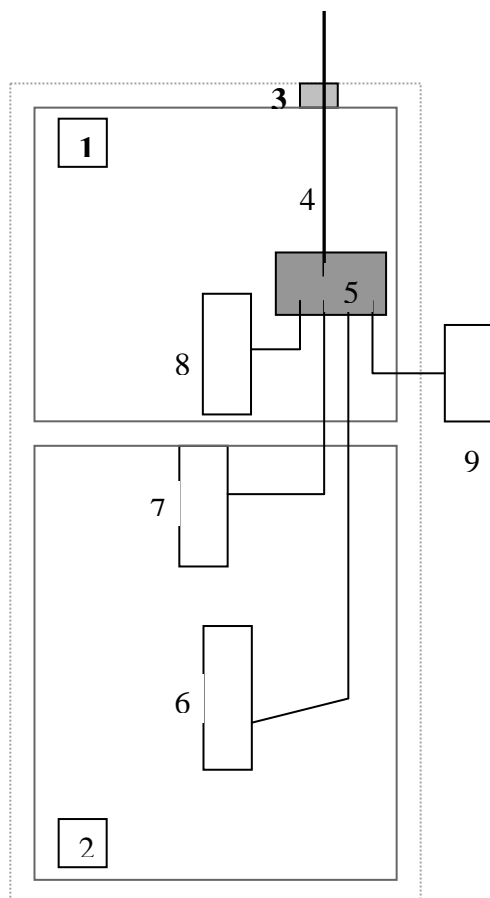

- 1 = Head slatted frame
- 2 = Feet slatted frame
- 3 = Relief device
- 4 = Power cable
- 5 = Control box
- 6 = Motor of slatted frame
- 7 = Motor of feet end
- 8 = Motor of head end
- 9 = Handset

All cables inside the bed frame, have been fitted in such a way that prevents contact with the floor as well as squashing or pinching.

3 Installation and adjustment

The instructions in this chapter are for the specialist dealer.

The Vermeiren Alois (Lo-Lo) has been designed to be adjust with a minimum of replacements parts. There is no need for extra stock of spare parts.

To find a service facility or specialist dealer near you, contact the nearest Vermeiren facility. A list of Vermeiren facilities can be found on the last page.

⚠ WARNING: Risk of unsafe settings - Use only the settings described in this manual.

3.1 Tools

To set up the bed the following tools are needed.

- Allen key
- Screwdriver

3.2 Manner of delivery

You have two options for the Alois (Lo-Lo) bed. You can choose a mattress base either with motorised knee hinge (997_AL) or without motorised knee hinge (998_AL), with wooden or metal side rails.

The Vermeiren Alois (Lo-Lo) shall be delivered with:

• Undercarriage with motor and control box	(970_AL)	Approx. 34 kg/piece
• Slatted frame, feet end incl. motor	} (997_AL)	Approx. 23 kg
• Slatted frame, head end incl. motor		Approx. 20 kg
• Slatted frame, feet end without motor	(998_AL)	Approx. 20 kg
• Head / Feet panel	(965_AL)	Approx. 7 kg
• Metal side railings	(989_AL)	Approx. 6 kg/piece
• Head / Feet panel	(965_110_AL)	Approx. 7 kg
• Wooden side railings (2 x 2 wooden slats)	(969_110)	Approx. 3 kg/piece
• Lifting pole + triangular grip	(988NL)	Approx. 8 kg
• Transport set	(981_AL)	Approx. 3 kg/piece
• Handset		Approx. 10 kg
• Holder for handset		
• Allen key (for assembly)	(incl. with 965_AL and 965_110_AL)	
• Instruction Manual		

The nursing bed may only be used with the parts listed here. If parts are omitted or if foreign furnishings, components or electrical systems are included, then this bed is not regarded as a nursing bed supplied by the manufacturer, and you use it at your own risk. Then the CE conformity and the warranty of the manufacturer do not apply.

3.3 Assembly

⚠ CAUTION: Chance of pinching - Do not place fingers between the components of the bed.

⚠ CAUTION: Risk of clamping - Keep fingers away from moving parts of the bed.

You should obey the assembly instructions of your nursing bed as explained below.

3.3.1 Undercarriage

1. Place the frame with the wheels on a level and non-porous base. Lock the four wheels by using the brake (see also chapter "Wheels").
2. Place the bracket with the bearings in the C-profile and screw in the other side.
3. Secure the motor (LA311779-00) with locking pins.

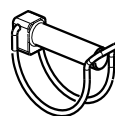
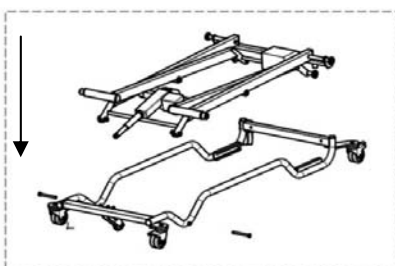

Locking pin

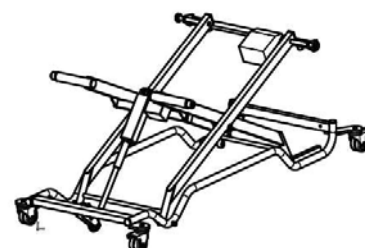

3.3.2 Head / Feet end

1. Place the head end with the C-profile over the bearing holders on the undercarriage. The bolt in the C-profile serves as a stop for the head end.
2. Push the feet end over the joining tubes of the head end. Join the feet end to the sub frame using locking pins.
3. Screw the mattress slatted frame into the joining tubes firmly using a screwdriver.

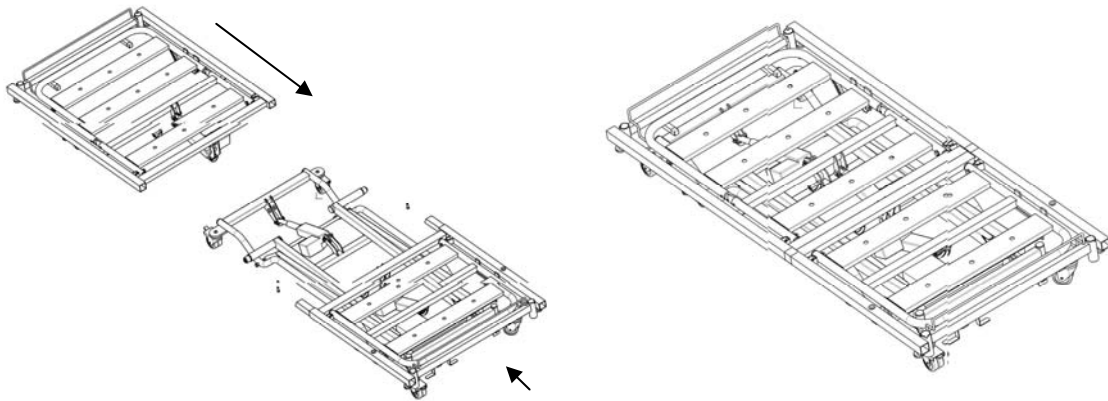

3.3.3 Metal side railings

⚠ WARNING: Chance of pinching - Make sure the motor wires are not tangled!

1. Slide the head and feet panels of the metal bed sides (965_AL) into the mattress slatted frame at the feet or head end of the bed. (The fixing screws must first be unscrewed). Make sure they are straight!) PLEASE NOTE: The mattress slatted frame has a cable grip for the power cable at the head end.
2. Screw both fixing screws firmly into the mattress slatted frame.
3. Take the other panel and the other side of the mattress slatted frame and repeat steps 1 and 2.

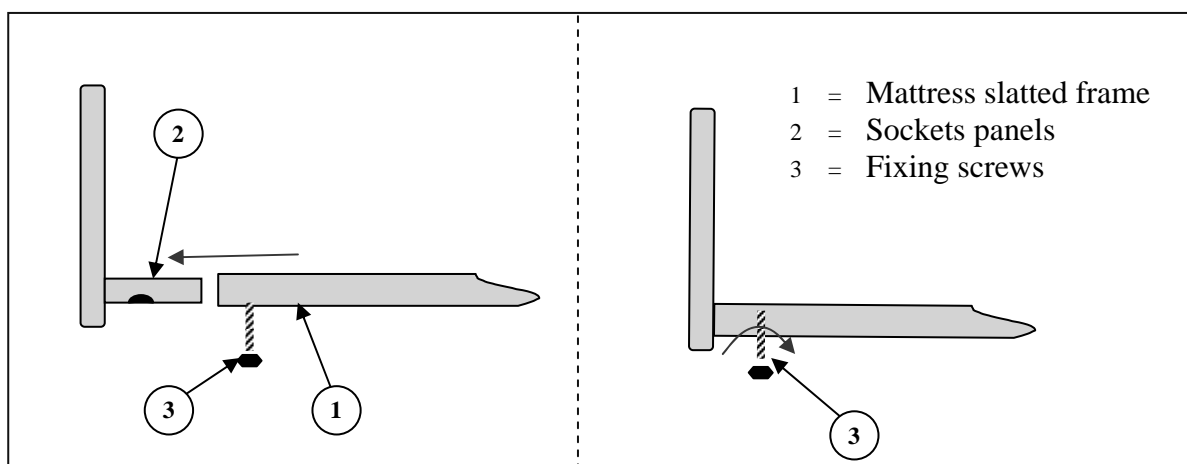

Fix everything in place with the fixing screws. Screw them in firmly until they are completely through the opening of the sockets of the panels and generate a gripping force (screw by hand!).

4. Assemble the assembled side rails (969_AL) on the bed. The metal side rails are attached straight on to the mattress slatted frame using the large star handles. The distance A1 or A2 between the end of the metal side rail and the wooden panel must be either max. 6 cm or min. 25 cm. An indication is also given on the metal side rails. You can lower a side rail by pulling down the handle (1) at the bottom of the side rail.

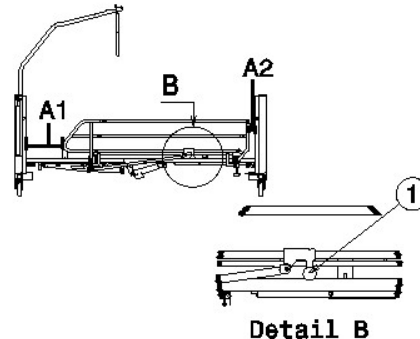

3.3.4 Wooden side railings

Wooden side railings are also available. The following provides a description of how to install the wooden side railings.

Adjust the height of the bed in the middle. With a too low height it is not possible to mount the side rails. With a too high height you must pull the side rails to far upwards.

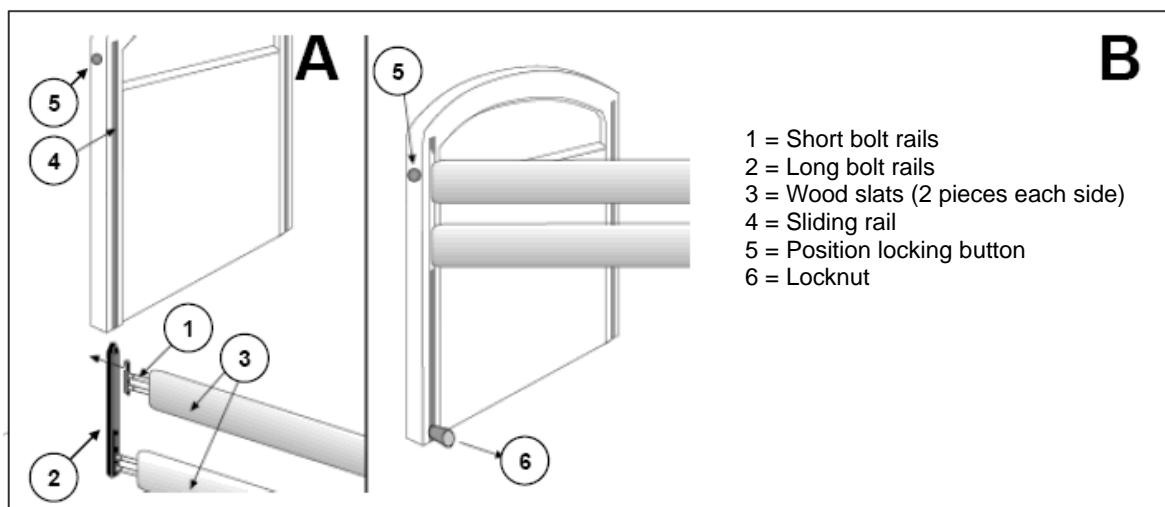

1. Slide the head or feet panels of the wooden bed sides (965_110_AL) into the mattress slatted frame at the feet or head end of the bed. (The locking screws must first be unscrewed).
Make sure they are straight!) PLEASE NOTE: The mattress slatted frame has attachment points for the power cable at the head end.
 2. Screw both locking screws firmly into the mattress slatted frame.
 3. Take the other panel and the other side of the mattress slatted frame and repeat steps 1 and 2.
- A.** Insert the short bolt rails (1) on the right and left in the upper wood slat. Insert the long bolt rails (2) right and left in the lower wood slat.
- Insert the short bolt rails (1) + the upper wood slat on one side (left or right) in the long bolt rails (2). Slide the entire bolt rail system (1) + (2) in the relevant sliding rail (4) from the head and feet end. Grasp the upper wooden slat upwards until the wooden side rail locks in position. Repeat these steps for the other side.

B. Insert the locknuts (6) and tighten them manually.

To release the wooden side rails press the locking button (5) and pull the upper wooden slat gently upwards.

3.3.5 Connections

⚠ CAUTION: Risk of injury - Do not touch the plug with wet hands.

⚠ CAUTION: Risk of injury - Do not place any objects on the connection and the cable, and protect these against mechanical loads.

1. A 220 V / 230 V, 50 Hz power socket conforming to the VDE specifications is required
2. The diagram for the control box connections is given in the figure below:

Take hold of the plug only to remove it from the power socket.

The power cable must be laid without any loops or kinks and should not pass around sharp edges.

The power cable leading to the manual switch must be protected against squashing.

The motor cables along the feet end and undercarriage must go through the round openings in the fastenings. Make sure the cables are raised from the ground wherever possible. This is to prevent damage to the cables.

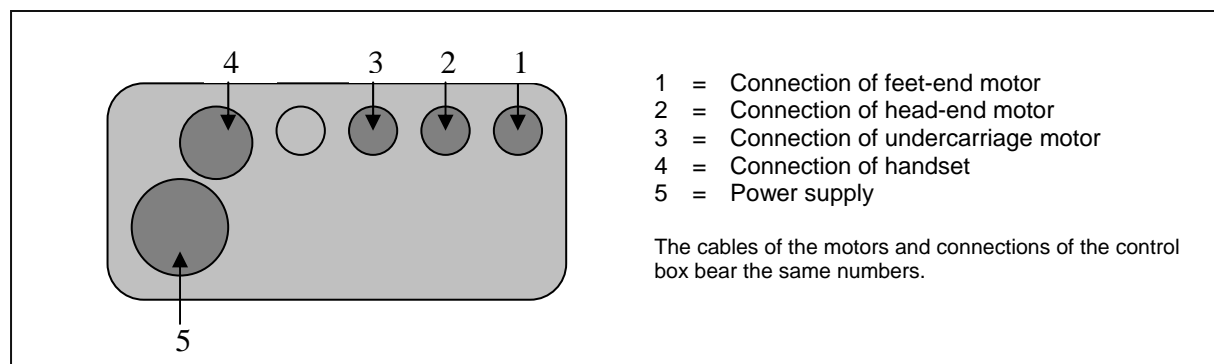

There is an equipotential connection under the mattress slatted frame. This serves to bring conductive parts to the same potential. This connection is connected to an earth cable.

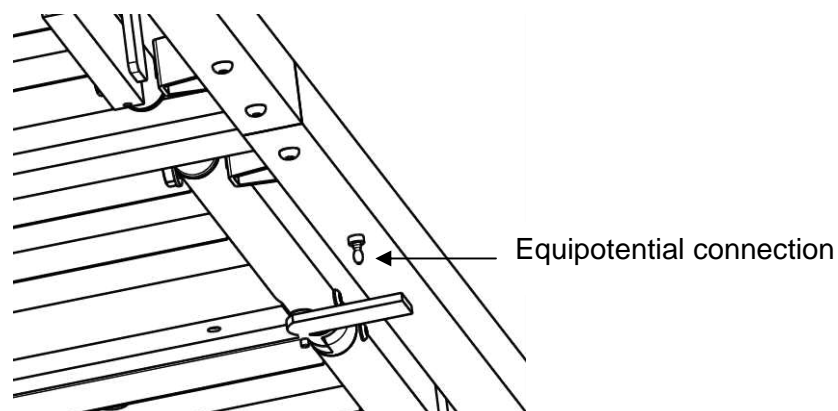

4 Maintenance

For the maintenance manual of the beds refer to the Vermeiren website: www.vermeiren.be.

5 Declaration of conformity

The manufacturer or his authorized representative :

N.V. VERMEIREN N.V

Address :

Vermeirenplein 1/15
2920 Kalmthout
Belgium

declares under his sole responsibility that the CE marked medical devices :

Productgroup:	Electric sick beds
Brand:	Vermeiren
Type:	Alois (Alzeis)

have been classified as class I, according to annex IX MDD 93/42/EEC, rule 12,

and is manufactured in full conformity with the European instructions below - including the latest modifications - and with the national law, that organizes this directions :

Medical devices directive MDD 93/42/EEC: 2007

and is in conformity with the relevant European harmonized standards:

EN 12182: 2012, EN 1970: 2000, EN 1970 A1: 2005



SERVICE

The bed was serviced:

Dealer's stamp:

Date:

Dealer's stamp:

Date:

Dealer's stamp:

Date:

Dealer's stamp:

Date:

Dealer's stamp:

Date:

Dealer's stamp:

Date:

Dealer's stamp:

Date:

Dealer's stamp:

Date:

Dealer's stamp:

Date:

Dealer's stamp:

Date:

- For service checklists an additional technical information, please see our specialist dealers nearest to you. More information on our website at: www.vermeiren.com.

Belgium

N.V. Vermeiren N.V.

Vermeirenplein 1 / 15
B-2920 Kalmthout
Tel: +32(0)3 620 20 20
Fax: +32(0)3 666 48 94
website: www.vermeiren.be
e-mail: info@vermeiren.be

France

Vermeiren France S.A.

Z. I., 5, Rue d'Ennevelin
F-59710 Avelin
Tel: +33(0)3 28 55 07 98
Fax: +33(0)3 20 90 28 89
website: www.vermeiren.fr
e-mail: info@vermeiren.fr

Italy

Reatime S.R.L.

Viale delle Industrie 5
I-20020 Arese MI
Tel: +39 02 99 77 07
Fax: +39 02 93 58 56 17
website: www.reatime.it
e-mail: info@reatime.it

Poland

Vermeiren Polska Sp. z o.o

ul. Łączna 1
PL-55-100 Trzebnica
Tel: +48(0)71 387 42 00
Fax: +48(0)71 387 05 74
website: www.vermeiren.pl
e-mail: info@vermeiren.pl

Czech Republic

Vermeiren ČR S.R.O.

Sezemická 2757/2 - VGP Park
193 00 Praha 9 - Horní Počernice
Tel: +420 731 653 639
Fax: +420 596 121 976
website: www.vermeiren.cz
e-mail: info@vermeiren.cz

Germany

Vermeiren Deutschland GmbH

Wahlerstraße 12 a
D-40472 Düsseldorf
Tel: +49(0)211 94 27 90
Fax: +49(0)211 65 36 00
website: www.vermeiren.de
e-mail: info@vermeiren.de

Austria

L. Vermeiren Ges. mbH

Winetzhammerstraße 10
A-4030 Linz
Tel: +43(0)732 37 13 66
Fax: +43(0)732 37 13 69
website: www.vermeiren.at
e-mail: info@vermeiren.at

Switzerland

Vermeiren Suisse S.A.

Hühnerhubelstraße 59
CH-3123 Belp
Tel: +41(0)31 818 40 95
Fax: +41(0)31 818 40 98
website: www.vermeiren.ch
e-mail: info@vermeiren.ch

Spain

Vermeiren Iberica, S.L.

Trens Petits, 6. - Pol. Ind. Mas Xirgu.
17005 Girona
Tel: +34 902 48 72 72
Fax: +34 972 40 50 54
website: www.vermeiren.es
e-mail: info@vermeiren.es